

# aiwa

**OPERATING INSTRUCTIONS  
MANUAL DE INSTRUCCIONES  
MODE D'EMPLOI**

# CT-X418 YU

**STEREO CAR CASSETTE RECEIVER  
RADIO-CASSETTE ESTEREOFONICO PARA AUTOMOVIL**

**ENGLISH**

## **OWNER'S RECORD**

For your convenience, record the model number and serial number (you will find them on the right side of your set) in the space provided below. Please refer to them when you contact your AIWA dealer in case of difficulty.

Model No.

Serial No.

## Welcome

Thank you for your purchasing this AIWA product. To optimize the performance of this unit, please read through this manual carefully.

In addition to this operating instructions manual, be sure to refer to the separate installation and connections manuals as well.

---

## PRECAUTIONS

---

- This unit is designed to be operated on a 12-volt DC negative-ground electrical system only.
- To prevent short-circuiting, disconnect the negative car battery terminal until the unit has been mounted and connected completely.
- When replacing the fuse, be sure to use one whose amperage rating is identical. Use of a fuse of higher amperage may cause serious damage to the unit.
- Keep screwdrivers, etc. and other metallic or magnetic objects away from the playback head.
- When your car was parked in direct sunlight resulting in a considerable rise in temperature inside the car, allow the unit to cool off before operating it.
- Keep the volume at such a level that you can hear outside warning sounds (horns, sirens, etc.).

### Notes on cassettes

Do NOT expose cassettes to direct sunlight, extremely high or cold temperature or moisture. Keep cassettes away from equipment with built-in magnets to avoid unwanted noise or loss of sound quality.

Do NOT touch the tape of a cassette, as any dirt or dust will contaminate the heads.

Be sure to remove any cassette from the unit if you are not using it.

## NOTE

This equipment has been tested and found to comply with the limits for a Class B digital device, pursuant to Part 15 of the FCC Rules. These limits are designed to provide reasonable protection against harmful interference in a residential installation.

This equipment generates, uses, and can radiate radio frequency energy and, if not installed and used in accordance with the instructions, may cause harmful interference to radio communications. However, there is no guarantee that interference will not occur in a particular installation. If this equipment does cause harmful interference to radio or television reception, which can be determined by turning the equipment off and on, the user is encouraged to try to correct the interference by one or more of the following measures:

- Reorient or relocate the receiving antenna.
- Increase the separation between the equipment and receiver.
- Connect the equipment into an outlet on a circuit different from that to which the receiver is connected.
- Consult the dealer or an experienced radio/TV technician for help.

## CAUTION

Modifications or adjustments to this product, which are not expressly approved by the manufacturer, may void the user's right or authority to operate this product.

### Caution on the transit protection pad

The unit is shipped with a transit protection pad in the cassette compartment.

Be sure to press EJECT ▲ to remove the pad before operation the unit.

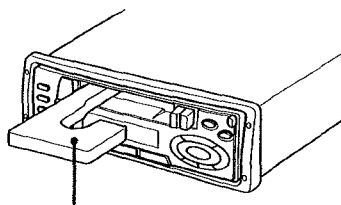

Transit protection pad

---

# TABLE OF CONTENTS

---

FRONT PANEL .....	3
DETACHING AND ATTACHING THE FRONT PANEL .....	4
SETTING THE BEEP TONE .....	5
SETTING THE CLOCK .....	5
RADIO OPERATION .....	6
PRESETTING STATIONS .....	7
TAPE PLAYBACK .....	8
SOUND ADJUSTMENTS .....	9
CRP (CD changer ready position) .....	10
CONNECTING A PORTABLE CD PLAYER OR OTHER EQUIPMENT .....	11
MAINTENANCE .....	12
SPECIFICATIONS .....	12

# FRONT PANEL

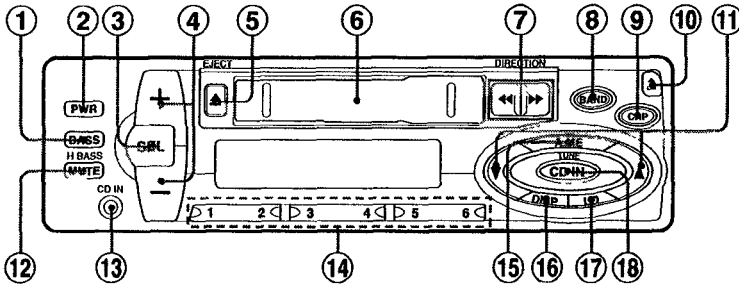

## Display window

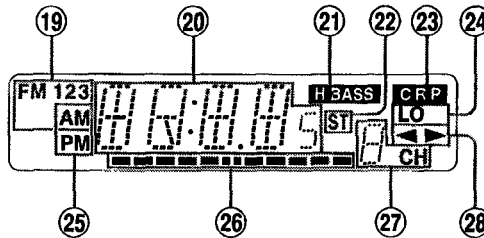

- |  |   |
|--|---|
| ① H-BASS button                          | ⑩ DISP (display) button                     |
| ② PWR (power on/off) button              | ⑪ LO (local/DX) button                      |
| ③ SEL (select) button                    | ⑫ CD IN button                              |
| ④ +/- (audio control) button             | ⑬ Band indicator                            |
| ⑤ EJECT button                           | ⑭ Main display section                      |
| ⑥ Cassette compartment                   | ⑮ H BASS indicator                          |
| ⑦ DIRECTION button                       | ⑯ ST (stereo) indicator                     |
| ⑧ BAND button                            | ⑰ CRP (CD changer ready position) indicator |
| ⑨ CRP (CD changer ready position) button | ⑱ LO (local) indicator                      |
| ⑩ Release button                         | ⑲ AM/PM indicator                           |
| ⑪ TUNE buttons                           | ⑳ Audio control indicator                   |
| ⑫ MUTE button                            | ㉑ Subdisplay section                        |
| ⑬ CD IN jack (3.5-mm dia.)               | ㉒ ◀▶ (tape direction) indicators            |
| ⑭ Preset station buttons 1-6             |   |
| ⑮ A. ME (auto memory/preset scan) button |   |

# DETACHING AND ATTACHING THE FRONT PANEL

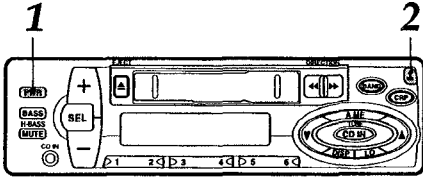

You can detach the front panel from the unit and carry it with you when you leave your car unattended.

When you carry the front panel out of your car, use the supplied carrying case.

Before detaching the front panel, remove the cassette to prevent possible damage to the unit.

- 1 Press **PWR** to turn the unit off.
- 2 While supporting the front panel with one hand, press **↑** to release one side of the panel. Care must be taken not to drop the panel. It may suddenly eject at this point.
- 3 When the front panel is lifted from the unit, remove it by pulling it away from the unit.

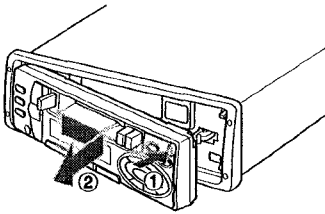

Do NOT touch the connector on the reverse side of the front panel, as doing so may contaminate the connector and cause a poor connection resulting in a malfunction.

## Attaching the front panel

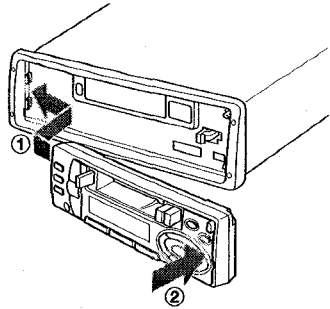

## Security Lamp

When the front panel is detached, you can find an LED lamp on the front side of the unit. This lamp is designed to deter theft, and continues to flash when the car's ignition is turned off with the front panel detached. This unit is not equipped with any other security systems such as a security alarm, so there are limitations to its effectiveness.

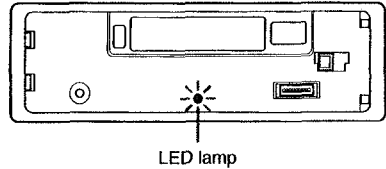

## SETTING THE BEEP TONE

The unit is preset at the factory to beep each time you press any button on the front panel except OPEN. You can stop beeping by following the procedure below.

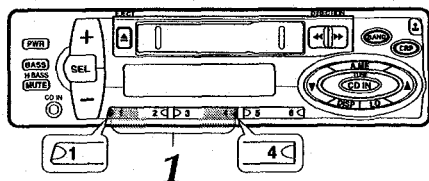

- 1 With the unit off, press 1 and 4 at the same time.

The "BEEP" indication appears.

Each time you press them, this function turns on or off.

The beep function is activated when the "BEEP" indication appears with the audio control indicator lighting up and deactivated without the indicator.

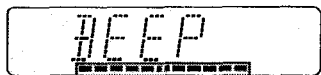

Audio control indicator

## SETTING THE CLOCK

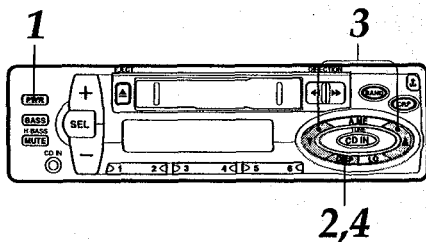

- 1 Press PWR.
- 2 Press and hold down DISP for more than 1.5 seconds until the clock indication flashes.

• If you do not proceed with step 3 within 5 seconds, the clock indication disappears.

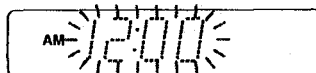

- 3 Press ▼ to set the hour.  
Press ▲ to set the minutes.
- 4 Press DISP to start working the clock from 0 second.

**Having the clock displayed while in Radio, Tape Play or CD Changer Play mode**

Press DISP. To return the unit to its former display, repeat the same procedure.

# RADIO OPERATION

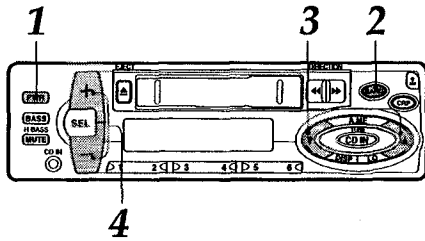

- 1 Press **PWR** to turn the unit on.  
The radio frequency appears.
- 2 Press **BAND** to select the band from among **FM1, FM2, FM3** and **AM**.  
The band indication appears cyclically in order.  
(FM1, FM2 and FM3 share the same frequency range.)

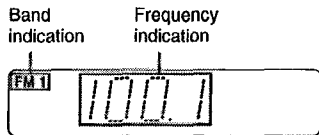

- 3 Press (more than 0.5 second) either **TUNE ▼** or **TUNE ▲** to tune in the desired station.  
Press ▼ to decrease and ▲ to increase the frequency.  
The unit starts scanning and tunes in a station automatically (Seek tuning).  
Press the button again to deactivate Seek tuning. Repeat the procedure until the desired station is tuned in.

**Note**

If you press (less than 0.5 second at a time) either **TUNE ▼** or **TUNE ▲**, the frequency decreases or increases step by step.

- 4 Adjust the volume with **+/-**.

**To turn the unit off**

Press **PWR**.

**Switching modes**

When the unit is in Radio mode, inserting a cassette switches the unit to Tape Play mode automatically.

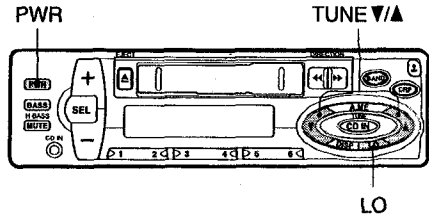

**LO (local/DX) button**

You can use Local mode when you wish to tune in only strong stations during seek tuning. In Radio mode, press **LO** to select Local mode. The "LO" indicator lights up.

- Press **LO** to deactivate Local mode and switch to **DX** (distance) mode.
- The "ST" (stereo) indicator lights up when the tuned-in station is broadcasting in stereo and the reception is good.

# PRESETTING STATIONS

## To preset stations automatically (auto memory)

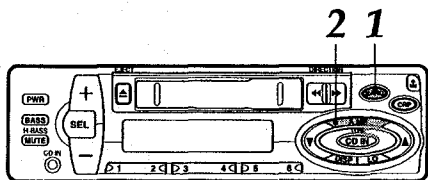

- 1 Press **BAND** to select a desired band from among FM1, FM2, FM3 and AM.

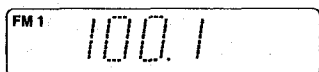

- 2 Press and hold **A.M.E.** for more than 1.5 seconds to activate the automatic presetting function.

The six strongest available stations will be stored in memory on the preset station buttons 1 to 6 in order of their signal strength.

Use this function to automatically preset up to 6 stations each for FM1, FM2, FM3 and AM (up to a total of 24 stations).

- When auto memory is completed, the station stored in 1CH is tuned in.
- To stop auto memory, press A.M.E. again.

### To check the preset stations (preset scan)

- If you wish to check the preset stations, press A.M.E. for less than 1.5 seconds. The preset stations stored in memory will be tuned in for 5 seconds each in order.
- To stop this function, press A.M.E. again or press any of the preset station buttons 1 to 6.

## To preset stations manually

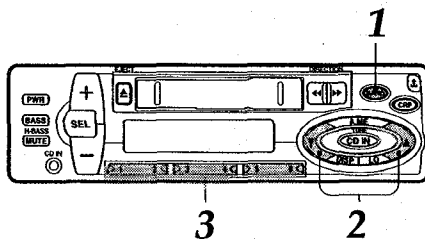

- 1 Press **BAND** to select the band from among FM1, FM2, FM3 and AM.
- 2 Tune in the station that you wish to preset with **TUNE ▼** or **TUNE ▲**.
- 3 Press one of the preset station buttons 1 to 6 for approximately 1.5 seconds. The number of the pressed preset station button appears next to the frequency indication.

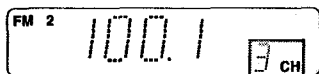

Preset number

Repeat these procedures to preset up to 6 stations each for FM1, FM2, FM3 and AM.

- You can manually preset stations that have not been selected by auto memory.
- If you try to preset a station on a preset station button on which another station of the same band has already been preset, the previously preset station will be erased.

During presetting of stations, beeps are heard regardless of the beep on/off setting (page 5).



## To tune in the preset stations

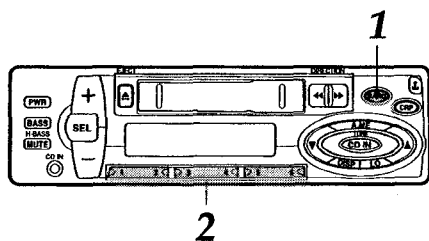

- 1 Press **BAND** to select a desired band from among **FM1, FM2, FM3** and **AM**.
- 2 Press the desired **preset station** button. The number of the pressed preset station button is displayed next to the frequency indication.

### Active tuning reception control (ATRC)

This unit automatically suppresses FM noise caused by varying signal strength resulting from movement of the car.

- The built-in automatic blending circuit mixes the left and right channel signals according to the strength of the reception. At the same time, the high-cut circuit activates to maintain the sound quality.
- If the reception becomes even weaker, the unit automatically switches to Monaural mode to reduce noise.

## TAPE PLAYBACK

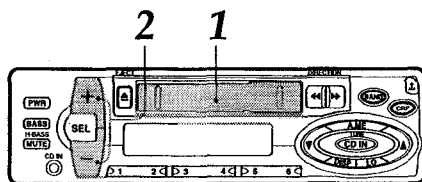

- 1 Insert a cassette to start playback. Playback starts in the direction that the unit played back previously.



- 2 Adjust the volume with **+/-**.

Press the following buttons to operate tape transport

To do this	Press this button
Eject the cassette*	
Change the playback side	and  simultaneously
Fast-forward upper side of the tape Rewind lower side of the tape	
Rewind upper side of the tape Fast-forward lower side of the tape	
Stop fast winding and resume playback	or  lightly**

\* When you eject the cassette, the unit switches to Radio mode.

\*\* Do not press or all the way. Doing so may change the direction of tape transport.

continued

## TAPE PLAYBACK

### Auto reverse function

When the end of the tape is reached during playback or fast tape transport, the direction of the tape is automatically reversed, and playback starts again.

### Tape direction indications

	Playback	Fast-forward or rewind
Upper side	▶	▶
Lower side	◀	▶

### Before turning the ignition off

Be sure to eject any cassette from the unit before turning the ignition off. Otherwise, the unit may be damaged when you detach the front panel.

### Switching modes

When the unit is in Radio mode, inserting a cassette switches the unit to Tape Play mode automatically.

### To prevent tape problems

Before inserting a cassette into the unit, make sure that there is no slack in the tape. If necessary, take up the slack by inserting a pencil into the spindle hole and winding. 90-minute or longer tapes are extremely thin and easily deformed or damaged. They are not recommended.

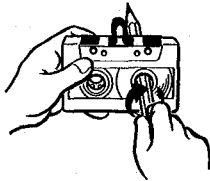

## SOUND ADJUSTMENTS

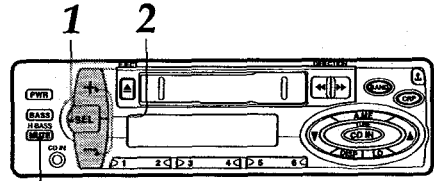

MUTE

- 1 Press SEL to select the mode that you wish to adjust from: VOL (volume), BAS (bass), TRE (treble), BAL (balance) and FAD (fader).

The following indications appear in cyclic order.

→VOL→BAS→TRE→BAL→FAD→

The selected mode switches to volume mode if you do not proceed with step 2 within 5 seconds.

- 2 Press +/- to adjust the level.

Press and hold either button to change the level rapidly.

Adjust each mode referring to the audio control indicators in the display window. (see page 3)

	-	+
VOL	Decreases the volume level	Increases the volume level
BAS	Decreases the bass level	Increases the bass level
TRE	Decreases the treble level	Increases the treble level
BAL	Decreases the level of the right speaker(s)	Decreases the level of the left speaker(s)
FAD	Decreases the level of the front speakers	Decreases the level of the rear speakers

Without selecting any mode with SEL, only the volume level can be adjusted by pressing +/-.

### MUTE button

Press this button to temporarily lower the volume.  
Press it again to restore the previous volume.

### H-BASS (High BASS)

You can enjoy music with strong bass sound.

H-BASS

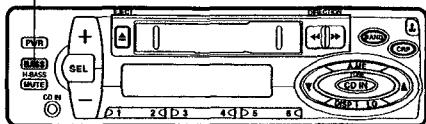

Press H-BASS to obtain powerful bass.  
The "H BASS" indicator lights up.  
Each time you press H-BASS, this function turns on or off.

## CRP (CD changer ready position)

You can enjoy CD changer play in combination with your RF-CD-changer system with easy operation.

### Presetting the frequency in accordance with the FM modulator supplied with the CD changer system

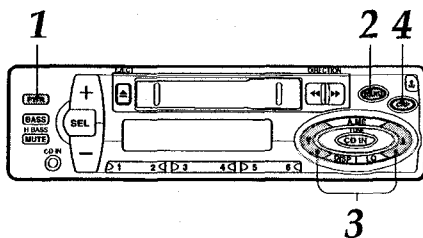

- 1 Press PWR to turn the unit on.**  
The radio frequency indication appears.
- 2 Press BAND to select the FM1 band.**
- 3 Press (less than 0.5 second at a time) either TUNE ▼ or TUNE ▲ repeatedly to tune in your FM modulator's frequency\*.**
- 4 Press CRP for more than 2 seconds to preset the frequency.**  
The "CRP" indicator flashes.  
Pressing TUNE ▼/▲ or any preset number button stores your setting in memory and the "CRP" indicator goes off.

\* Tune in 88.7 MHz or 89.1 MHz for Aiwa brand's compact disc changer system. This unit is preset in 88.7 MHz at the factory.

### Note

You can not preset your setting in the following cases.

- when you select a band except FM1.
- when a cassette is inserted in the unit.
- when the unit is in CD IN mode.

continued

## CRP (CD changer ready position)

### CD changer play

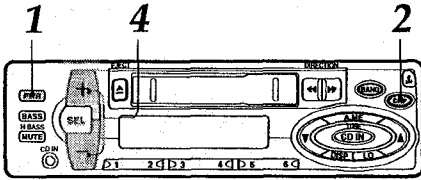

- 1 Press PWR to turn the unit on.**  
If a cassette is inserted, remove it to prevent possible damage to the unit.
- 2 Press CRP to switch the unit to CRP mode.**  
The "CRP" indicator lights up.
- 3 Play a CD with your CD changer system.**
- 4 Adjust the volume with +/-.**

#### To stop CD changer play

1. Press CRP.
2. Turn off your CD changer system.

#### To turn the unit off

Press PWR.

## CONNECTING A PORTABLE CD PLAYER OR OTHER EQUIPMENT

This unit is equipped with the line-level input (CD IN) jack enabling high quality of the sound.

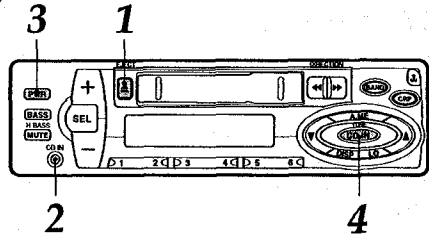

- 1 If a cassette is inserted, remove it to prevent possible damage to the unit.**
- 2 Connect a portable CD player, etc. via the CD IN jack (3.5-mm dia.) on the unit.**
- 3 Press PWR to turn the unit on.**
- 4 Press CD IN to listen to the connected equipment.**  
The "CD" indication appears.

•For further information on the connected equipment, refer to the operating instructions for the equipment.

#### Note

Be sure to press CD IN after you connect a portable CD player, etc. to the CD IN jack to listen using the connected equipment. Even if equipment is connected to the CD IN jack, you cannot listen using the connected equipment without switching the unit to CD IN mode by pressing CD IN.

---

# MAINTENANCE

---

## Cleaning the front panel

When the front panel is soiled, wipe the surface of the panel with a dry and soft cloth.

## Cleaning the tape head

Use a cleaning cassette to clean the playback head and capstans approximately once a month. If the playback head is dirty, the high tones may not be reproduced properly.

## Cleaning the connector

The connector on the reverse side of the front panel needs to be cleaned occasionally. Wipe the surface of the connector with a cotton swab slightly moistened with alcohol.

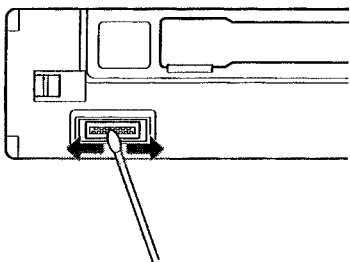

---

# SPECIFICATIONS

---

## RADIO SECTION

### (FM)

Frequency Range: 87.5 MHz–108 MHz  
(100-kHz steps)  
87.5 MHz–108 MHz  
(50-kHz steps)

Usable Sensitivity: 12.7 dBf  
50 dB Quieting Sensitivity: 17.2 dBf

IF Rejection: 80 dB  
Frequency Response: 30 Hz–15,000 Hz  
S/N Ratio: 63 dB  
Stereo Separation: 35 dB at 1 kHz  
Alternate Channel Selectivity: 70 dB

Capture Ratio: 3 dB

### (AM)

Frequency Range: 530 kHz–1,710 kHz  
(10-kHz steps)  
522 kHz–1,620 kHz  
(9-kHz steps)

Usable Sensitivity: 30  $\mu$ V (30 dB)

## TAPE SECTION

Wow/Flutter: 0.1% (WRMS)  
Tape Speed: 4.8 cm/sec. (1  $\frac{7}{8}$  ips)  
S/N Ratio: 50 dB  
Frequency Response: 40 Hz–14,000 Hz  
Stereo Separation: 40 dB  
FF/REW Time: 190 sec. (C-60)

## AUDIO SECTION

Max. Power Output: 40 W  $\times$  4 channels

## CD IN input

Input sensitivity (load impedance)  
CD IN: 500 mV (10 k $\Omega$ )

## GENERAL

Power-Supply Voltage: 14.4 V (11 to 16 V allowable),  
DC, negative ground

Load Impedance: 4  $\Omega$

Tone Control: Bass  $\pm$  10 dB at 100 Hz  
Treble  $\pm$  10 dB at 10 kHz

Preamp Output Voltage (load impedance):  
2.2 V (10 k $\Omega$ )

Installation size: 182 (W)  $\times$  53 (H)  $\times$   
155 (D) mm  
(7  $\frac{1}{4}$  (W)  $\times$  2  $\frac{1}{8}$  (H)  $\times$   
6  $\frac{1}{8}$  (D) inches)

Accessory supplied: Carrying case (1)

- Specifications and external appearance are subject to change without notice due to product improvement.





